

SWITCHED MODE POWER SUPPLY SERIES SMPS

Ordering Information:

24AS244D6D
24AS126D6D



PRODUCT DESCRIPTION:

GIC introduces a range of Din-rail/Base mountable, Single Phase Switching Power Supplies available in ratings of 12VDC, 72W & 24VDC, 96W. Features like high output accuracy with superior load & line regulations, with an input voltage range from 160 to 265 VAC, makes these power supplies an ultimate choice for any industrial application.

FEATURES:

- > Wide input voltage range
- > Excellent load & line regulation.
- > No load Power consumption of 0.5W max.
- > Output over voltage & Short circuit protection.
- > High noise Immunity & Low ripple.
- > High efficiency of Operation.
- > Suitable for operating temperature up to 550 C.
- > Finger safe terminals.
- > DIN- rail as well as base mounting facility.

CAUTION:

- > Do not touch the terminals while power is being supplied.
- > Tighten terminal screws with the specified torque.
- > Always follow instructions stated in product leaflet.
- > Before installation, check to ensure that specifications agree with intended application.
- > During installation, keep 10mm distance on both sides of product from adjacent devices.

SUITABILITY FOR USE:

These are products with Auto reset, hence never use the products for an application involving significant risk to life without ensuring that the system as a whole has been designed to address the risks and that our products are properly rated and installed for the intended use within the entire system or equipment.

NOTE:

- > All parameters, not specially mentioned are measured at 230 VAC input, rated load and 250 C of ambient temperature.
- > *Ripple & noise are measured at 20 MHz of oscilloscope band width with shortest length of probe terminals.
- > *The efficiencies are measured at nominal input voltage (230 VAC) by connecting rated load at 250 C ambient temperature.
- > *It is not recommended to operate the power supply at this load for more than 5 sec.
- > The power supply shall not be used to charge batteries.
- > In case of No-load & light loads (~10%) an audible noise may be heard which is not harmful.
- > *The output shuts down and Automatically attempts to restart.

Product innovation being a continuous process, we reserve the right to alter specifications without any prior notice.

FUNCTION DESCRIPTION:

Cat. No.:	24AS244D6D	24AS126D6D
INPUT CHARACTERISTICS:		
Supply Voltage	230 VAC	
Supply Voltage Tolerance	-30 % ; +15 % of \varnothing	
Frequency	50 Hz, (\pm 3 Hz)	
AC Input Current (Max.)	1.2 A	1 A
Consumption Without Load	0.5 W Max.	
Inrush Current (Typ)	50 A Peak at cold start	
OUTPUT CHARACTERISTICS:		
DC Voltage	24 V (Single Output)	12 V (Single Output)
Output Indication	Green LED ON	
Current Range	0 to 4A	0 to 6A
Rated Power	96 W	72 W
Load Regulation	\pm 1 %	
Line Regulation	\pm 1 %	
Output Voltage Accuracy	\pm 1 %	
Start Up Time	3 Sec Max (At minimum specified input voltage and rated load)	
Hold UP Time	> 30 ms	
Ripple & Noise (max).	150 mVp-p ¹²	100 mVp-p ¹²
Efficiency	> 89 % ¹³	> 86 % ¹³
Short term overload Capacity	125 ~ 160 % ¹⁴	105 ~ 135 % ¹⁴
PROTECTIONS :		
Over Voltage	26 V ~ 33 V	13 V ~ 16 V
	Protection Type: Hiccup mode ⁷ , Auto recover.	
Short Circuit	Hiccup mode & Auto Recover after removal of short.	
Internal Input Fuse	3.5 A / 250 V, Slow Blow	
AMBIENT CONDITIONS		
Operating Temperature	-10° C to + 55° C	
Storage Temperature	-25° C to + 85° C	
Relative Humidity	5 to 95 % (Non-Condensing)	
Operating Positions	Vertical & Horizontal on Top	
Degree of Protection	IP 30 (Enclosure); IP 20 (Terminals).	
Pollution Degree	II	
OTHERS		
Case Material	UL 94-V0 Plastic	
Mounting	Base / Din-Rail	
Dimensions (W X H X D)	105 x 90x 58 (in mm)	
Weight (unpacked)	350 g	
Enclosure	Flame Retardant UL94-V0	

PEAK CURRENT CAPABILITY:

Cat No: 24AS244D6D: for 24 V, 96 W

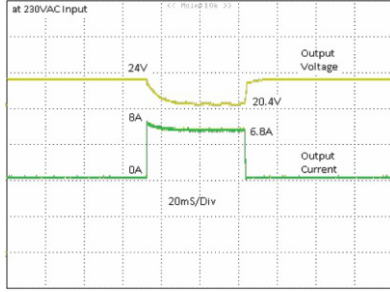

Peak load 8A(resistive) for 50mS
Output voltage dips from 24V to 20.4V

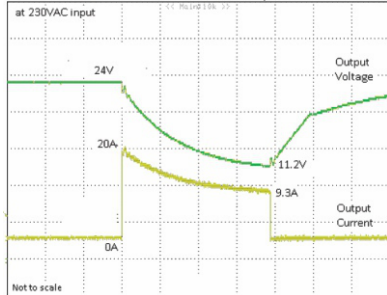

Peak load 20A (resistive) for 5 ms
Output voltage dips from 24V to 11.2V

Cat No: 24AS126D6D: for 12 V, 72 W

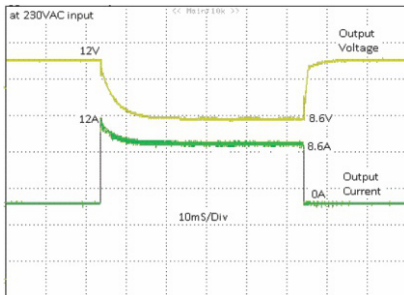

Peak load 12A (resistive) for 50ms
Output voltage dips from 12V to 8.6V

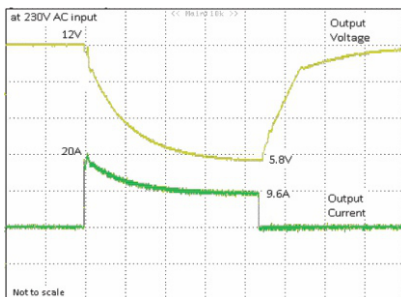

Peak load 20A (resistive) for 5 ms
Output voltage dips from 12V to 5.8V

Input	Output voltage dips (typ.)	Load current & Duration
160VAC	From 24V to 18.0V	at 8A for 50mS, Res.load
	From 24V to 10.4V	at 20A for 5mS, Res.load
230VAC	From 24V to 20.4V	at 8A for 50mS, Res.load
	From 24V to 11.2V	at 20A for 5mS, Res.load
265VAC	From 24V to 21.4V	at 8A for 50mS, Res.load
	From 24V to 11.5V	at 20A for 5mS, Res.load
Input	Output voltage dips (typ.)	Load current & Duration
160VAC	From 12V to 7.5V	at 12A for 50mS, Res.load
	From 12V to 5.5V	at 20A for 5mS, Res.load
230VAC	From 12V to 8.6V	at 12A for 50mS, Res.load
	From 12V to 5.8V	at 20A for 5mS, Res.load
265VAC	From 12V to 9.0V	at 12A for 50mS, Res.load
	From 12V to 6.0V	at 20A for 5mS, Res.load

Incase of any query, please write us at service@gicindia.com

Or visit www.gicindia.com

EMI / EMC:

Harmonic Current Emissions	IEC 61000-3-2 Class A
ESD	IEC 61000-4-2 Level II
Radiated Susceptibility	IEC 61000-4-3 Level III
Electrical Fast Transient	IEC 61000-4-4 Level IV
Surge	IEC 61000-4-5 Level IV
Conducted Susceptibility	IEC 61000-4-6 Level III
Voltage Dips & Interruptions (AC)	IEC 61000-4-11 Performance Criteria B
Conducted Emission	CISPR11 Class A

Safety:

Test Voltage between I/P and O/P	IEC 60947-5-1 3 kv
Test Voltage between all terminals and enclosure	IEC 60947-5-1 4 kv
Impulse Voltage between I/P and o/p	IEC 60947-5-1 Level IV
Single Fault	IEC 61010-1
Insulation Resistance	UL 508 > 50 kΩ
Leakage Current	UL 508 < 3.5 mA

Environmental:

Cold Heat	IEC 60068-2-1
Dry Heat	IEC 60068-2-2
Vibration	IEC 60068-2-6 5 g

AWG	CURRENT (A)
12	5.00
14	3.33
16	1.67

OVERALL PRODUCT DIMENSIONS AND MOUNTING DETAILS:

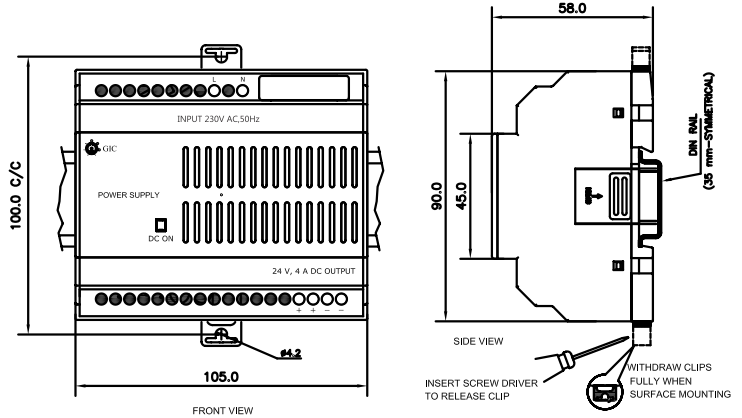

TERMINAL DETAILS:

	Torque 0.54 N.m (5 Lb.in) Terminal screw - M2.6
	1 x 0.2...3.3 mm ² Solid Wire
AWG	1 x 24 to 12

Use Cu wire of 75°C only.

Incase of any query, please write us at service@gicindia.com
Or visit www.gicindia.com

E-Waste
Regulatory
notice:
Kindly treat,
recycle or
dispose of this
equipment in an
environmentally sound
manner after End of Life, as
per WEEE
(Waste Electrical and
Electronic Equipment)
regulations;
or hand it over to General
Industrial Controls Pvt. Ltd,
through website
[https://www.gicindia.com/
get-in-touch/](https://www.gicindia.com/get-in-touch/)

