

DIGITAL HOUR METER COUNTER



Ordering Information:

Z2301N0G1FT00
Z2221N0G2FT00



FEATURES:

- Suitable for Hour meter & Counter (Up / Down) application
- Wide Hour meter range from 1 sec to 9999999 hrs.
- Wide counter range from 1 to 9999999 counts.
- Prescaling facility for Counter.
- Alarm facility for both Hour meter & Counter.
- MOSFET Output with Over Load detection.
- Retentive & Non-Retentive modes.
- 7 Digit LCD with luxurious green backlight.
- Password protection for device setting.
- Compact size with panel mounting facility.

CAUTION:

- Do not touch the terminals while power is being supplied.
- Tighten terminal screws with the specified torque.
- Always follow instructions stated in product leaflet.
- Before installation, check to ensure that specifications agree with intended application.
- During installation, keep 10mm distance on both sides of product from adjacent devices.
- Suitable dampers should be provided in the event of excessive vibrations.
- Only qualified persons are authorized to install the product.
- Use slow blow fuse of 250mA rating in series with product supply.
- Device should be kept away from wet, dust & humidity environments.
- Device manufacturer will not be responsible if any incident occur due to negligence of cautions.

SUITABILITY FOR USE:

These are products with Auto reset, hence never use the products for an application involving significant risk to life without ensuring that the system as a whole has been designed to address the risks and that our products are properly rated and installed for the intended use within the entire system or equipment.

NOTE:

The technical information provided in this document was correct at the time of publish.
Product innovation being a continuous process, we reserve the right to alter specifications without any prior notice.

E-Waste Regulatory notice:
Kindly treat, recycle or dispose of this equipment in an environmentally sound manner after End of Life, as per WEEE (Waste Electrical and Electronic Equipment) regulations;
or hand it over to General Industrial Controls Pvt. Ltd, through website <https://www.gicindia.com/get-in-touch/>



CONNECTION DIAGRAM:

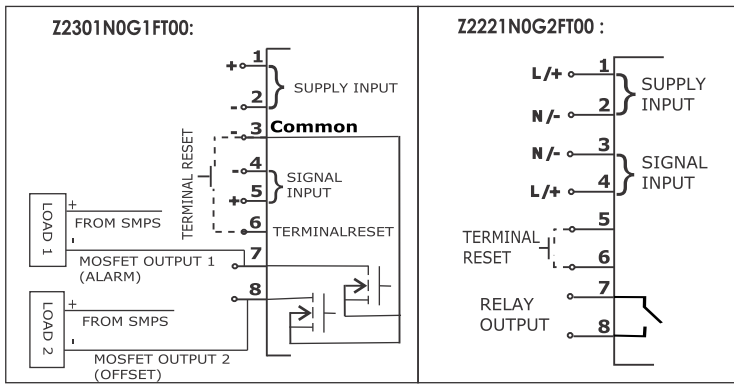

PROXIMITY SWITCH CONNECTION DIAGRAM:

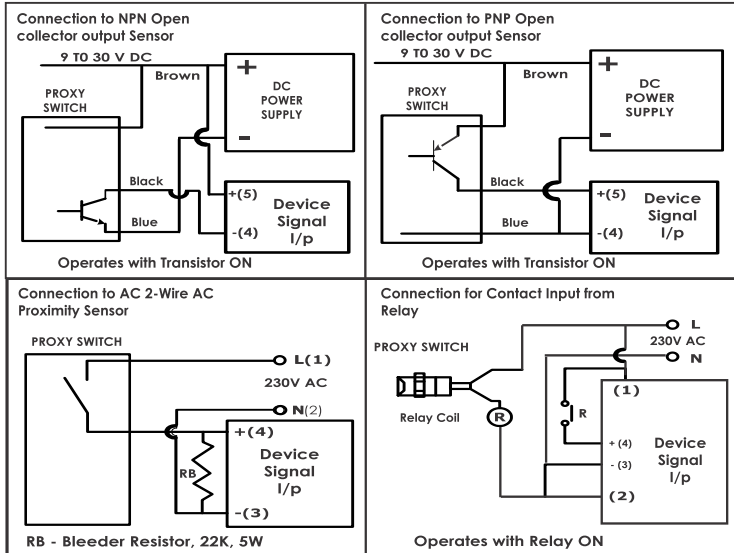

NOTE: In PNP & NPN proximity switch connection diagram mention wire color (Brown, Blue & Black) as per required connection for your reference only.

Using MOSFET O/P as signal I/P to External system

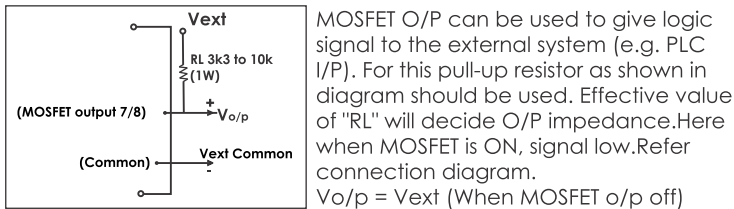

Overall Product Dimensions & Mounting Details (in mm)

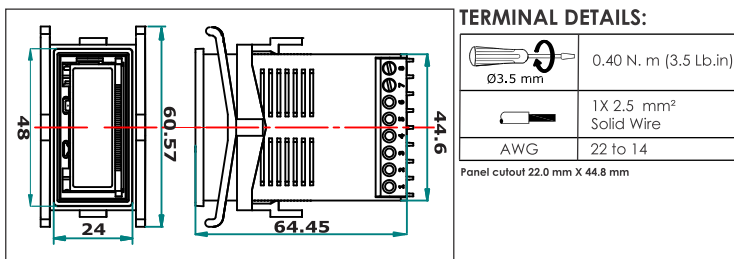

FRONTVIEW:

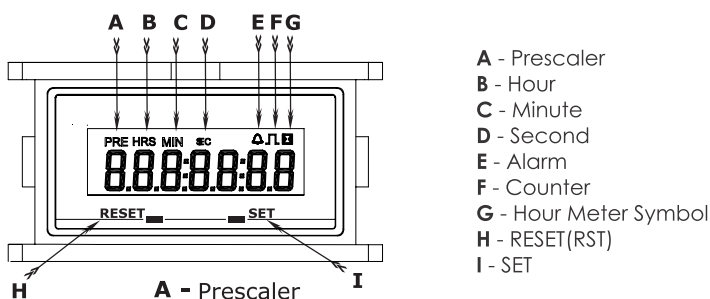

SYMBOL MEANING:

Symbol	Meaning
	Hourmeter - Blinking symbol means signal present.
	Counter - Product is in counter mode.
	Still symbol- Alarm is configured Blinking symbol- At alarm value reached.
PRE	Prescaler - Prescaler greater than 1 is selected.

KEY FUNCTIONS & DETECTION TIME:

Key	Edit mode & Detection Time	Run mode & Detection Time
SET	To save or shift to next digit 50 ms Minimum.	O/P OFF in Hour Mode O/P OFF in Latch mode of Counter As ACK - 2 sec Minimum. Quick EDIT mode entry >= 5 sec
RESET	To edit Parameter value 50 ms Minimum.	To reset count if front reset is enabled. Reset functionality >= 2sec

Product Catalog Number	Z2301NOG1FT00	Z2221NOG2FT00
Supply Characteristics:		
Supply Voltage Range (U _{in})	9 to 30 VDC	85 to 265 VAC/VDC
Power Consumption	2 W max.	2VA / 1W
Supply Frequency	50/60 Hz	

I/P Signal Characteristics:		
Signal Voltage Range	9 to 30 VDC	85 to 265 VAC & 100 to 265 VDC
Signal Isolation	2kv	

Output Characteristics:		
Output type	2MOSFET: 30 VDC/60 mA (Max.) Note: Use isolated input supply	Relay: 1N/O, Contact Rating: 5 A (Res.)@250 VAC/30VDC Contact Material: Ag Alloy

Functional Characteristics:				
Display	7 digit LCD, 6.5 mm Height, 12 O' Clock, transmissive			
Number of keys	2 (SET key & RST key)			
Reset function	Reset type	Terminal	Front	Auto Reset
	Time (minimum)	80 ms	3 Sec	-

Hour Meter Functions	
Accuracy	+/- 2 Sec per day
Ranges	Hrs: Min: Sec (999:59:59), Hrs: Min(99999:59), Hrs (9999999), Min (9999999), Sec (9999999)
Input Signal	Refer Note1

Counter Functions		
Accuracy	100 %	
Range	1 to 9999999.999 (max. 7 digits are visible)	
Decimal Point Position (max.)	3	
Pre-scaler	4-Digit	
Input Signal	Switching Freq.(max.)	10 Hz for AC and 40 Hz for DC
	Pulse Width min.	50ms ON/50ms OFF for AC, 12.5ms ON/12.5ms OFF for DC

Environmental Characteristics :	
Operating Temperature	-5° C to +55° C
Storage Temperature	-10° C to +60° C
Humidity	5 to 95% Rh (Without condensation)
Maximum Operating Altitude	2000 m
Pollution Degree	II
Degree of Protection	Front side: IP40; Terminals: IP20, Housing : IP30
Enclosure material	UL 94 V0 Plastic
Casing color	Black

Other Characteristics :	
Mounting	Flush mounting on panel cut-out
Panel Cut-out	22mm X 44.8mm
Weight (Un-packed)	52 gm
Operating Position	Horizontal
Termination wire Sizes	Wire size : 22-14 AWG, 0.3-2.5 mm

EMI/EMC Compliance:		
Harmonic Current Emissions	IEC 61000-3-2	Class A
Voltage Flicker & Fluctuation	IEC 61000-3-3	Class A
ESD	IEC 61000-4-2	Level II
Radiated Susceptibility	IEC 61000-4-3	Level III Criteria B
Electrical Fast Transients(Supply)	IEC 61000-4-4	Level IV
Electrical Fast Transients(Signal)	IEC 61000-4-4	Level III
Surge	IEC 61000-4-5	Level III
Conducted Susceptibility	IEC 61000-4-6	Level III
Power Frequency Magnetic Field	IEC 61000-4-8	Class 4
Voltage Dips	IEC 61000-4-29	Class B
Conducted Emission	CISPR 11	Class A
Radiated Emission	CISPR 11	Class A

Safety Compliance:		
Test Voltage (All terminal to housing)	UL 508	1.5 kV
Single fault	IEC 61010-1	
Leakage Current	UL 508	<3.5 mA

Environmental Compliance:		
Cold Heat	IEC 60068-2-1	
Dry Heat	IEC 60068-2-2	
Vibration	60068-2-6	5 g
Repetitive Shock	IEC 60068-2-27	40 g, 6 ms
Non-repetitive Shock	IEC 60068-2-27	30 g, 15 ms

FREQUENTLY ASKED QUESTIONS:

Q1. How can I change the device mode from Counter to Hour Meter or vice versa ?

Ans: To change the device mode from counter to hour meter or vice versa, it is required to reset the device, then in edit mode select the respective mode.

Q2. How to Reset the Counter/Hour meter, if 'Reset' is disabled?

Ans: If user disables Reset and save the setting, after that again user enables reset then only Terminal reset option is available to user. User has to enable the terminal reset, then reset the device count/time by shorting terminal reset pin & common ground pin. After this only user will see all reset settings in Edit menu.

Q3. What should I do when device flashes the Roll over message?

Ans: This means, device display limit is rolled over, then reset the count/time or change the resolution. **rol 0ur**

Q4. What should I do when device flashes the Over load message?

Ans: This means, that two MOSFET output device is over loaded. In output ON condition, when over load condition is occurs then "oL alarm" or "oL ofset" is displayed in two MOSFET device only, output is turned OFF. Press set key for >=2 sec to see the normal screen & make sure that connected load current should not be greater than 60mA. When both output are ON and both at over load condition then "oL both" screen will display. **oL ALAr n, oL ofSet, oL both**

Environmental Characteristics :	
Operating Temperature	-5° C to +55° C
Storage Temperature	-10° C to +60° C
Humidity	5 to 95% Rh (Without condensation)
Maximum Operating Altitude	2000 m
Pollution Degree	II
Degree of Protection	Front side: IP40; Terminals: IP20, Housing : IP30
Enclosure material	UL 94 V0 Plastic
Casing color	Black

Optional Accessory: ZF1907P: This is the Adapter plate suitable for mounting the Digital counter Hour meter, in panel cutout of 50mm x 25mm with counter sunk M4 screw fitting with vertical center to center distance of 38.2mm.

NOTE 1. For Hour counting detection, Signal has to be present for minimum 3msec and absent for minimum 20msec. e.g. 1. If the signal has 5 msec ON & 30 msec OFF, 5 msec time will keep on accumulating for every pulse. 30 msec off period will be considered as zero. 2. If signal has 3 msec ON time & 17 msec off time, then this full period (3+17=20msec) will be treated as signal present and time will be calculated for full period of signal presence.

Hour Meter Flow:

To enter in edit mode, Press SET & RESET key simultaneously for >=2 sec. Product firmware version is displayed for approx. 800ms and then password screen (Scr 0) will displayed only if password enabled otherwise Scr 1 is displayed. User can try only 3 times to enter password. After 3 attempts, if entered password is wrong then device will go in RUN mode. If user enter the correct password then Scr 1 is displayed.

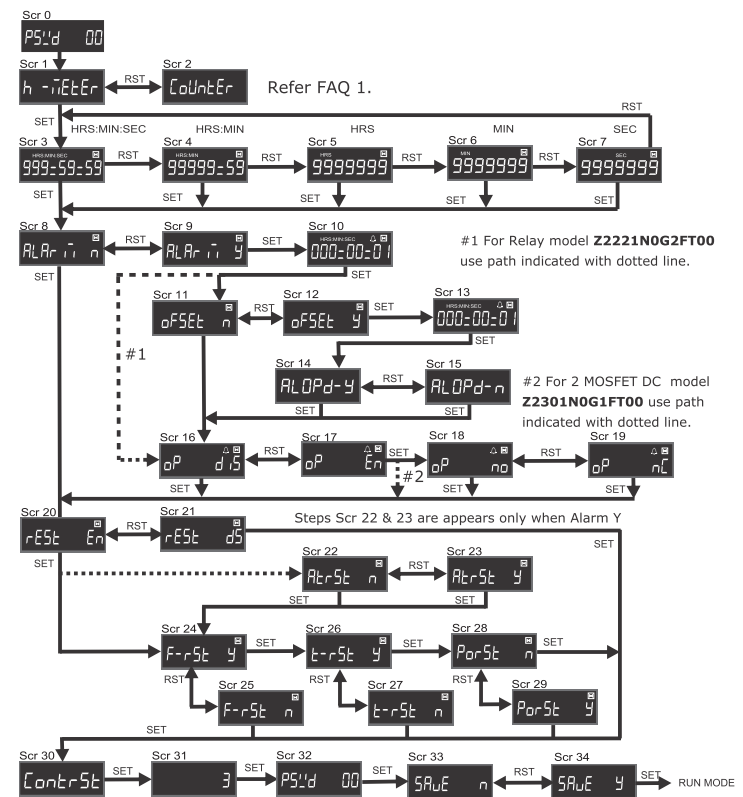

Quick access for Alarm & Offset preset value edit:

1. Press "SET" key for >=5sec.
2. If ALARM is disabled then device will show "ALARM N" and back to RUN mode (Home screen).
3. If ALARM is enabled then device will show first "ALARM Y" and then show the current Presetvalue (eg. 000:00:10).
4. After that, by using SET and RESET key user can set Alarm preset value.
5. After setting the alarm value, if the device is two MOSFET and hour meter is set then according to offset y/n setting, 'Offset Y' or 'Offset N' screen will be displayed for 500msec and then the offset value will be displayed for edit, otherwise, alarm value will be saved and device will come out of EDIT mode and goes to RUN mode.
6. After setting the offset value the device will save these two values and come out of edit mode and goes to Run mode.

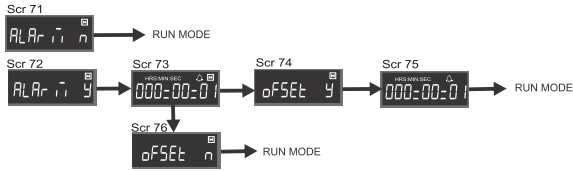

Mode selection:

Set Hour meter mode as per required resolution. Refer (Scr 3 to Scr 7). If the resolution is changed in RUN mode then hour meter shows time change as per selected mode.

Alarm value selection:

To set alarm value Press SET key to select each digit & press RESET key to edit the digit. Press SET key. The next digit starts blinking, after modifying last digit all digits starts blinking. Press SET to set the Alarm time. Refer Scr 8 to Scr 10

Note: Alarm is of recurring type alert. Recurring alert occurs continuously at a pre-defined period. It is Start to Start type. After changing Alarm value, if new Alarm value less than Current value then, output will turn on at display value equal to (Current value + alarm value). If new alarm value is greater than current display value, then output turns when alarm value is reached. Set Hour meter mode as per required resolution. Refer (Scr 3 to Scr 7). If the resolution is changed in RUN mode then hour meter shows time change as per selected mode.

Alarm output dependency: This is the dependency of offset output with alarm output. If ALoPd Y is selected then, Offset output is acknowledged before turning ON the alarm output, then alarm output will not turn ON when alarm value is reached. If ALoPd n is selected then alarm output will turn ON at alarm value reached. Refer Scr 14 to Scr 15

Offset value selection: User can select offset output with Alarm output. Offset value should not be greater than or equal to Alarm value. While editing the offset value, care has been taken to avoid the selection of such value. i.e. If offset value is greater than or equal to Alarm value then it will not accept. Refer Scr 11 to Scr 13

Alarm output dependency: Alarm output dependency: This is the dependency of offset output with alarm output. If alopd y is selected then, Offset output is acknowledged before turning ON the alarm output, then alarm output will not turn ON when alarm value is reached. If ALoPd n is selected then alarm output will turn ON at alarm value reached. Refer Scr 14 to Scr 15

Offset value selection: User can select offset output with Alarm output. Offset value should not be greater than or equal to Alarm value. While editing the offset value, care has been taken to avoid the selection of such value. i.e. If offset value is greater than or equal to Alarm value then it will not accept. Refer Scr 11 to Scr 13

Output Enable/Disable: Using this setting output can be made either enabled or disabled. When output is **Enable** then the output will activate and alarm symbol will blink. Output Enable: oP - nD and oP - nC applicable for output enable. If select oP - nD it turns 'ON' output when activated & 'OFF' when deactivated. If select oP - nC it turns 'OFF' output when activated & 'ON' when deactivated. When output is **Disable** then the output will be OFF and alarm symbol will blink.

NOTE: When output is enabled, MOSFET or Relay output turns ON when alarm value is reached. When output is disabled, MOSFET or Relay output remains OFF even when alarm value is reached. Alarm symbol blinks when alarm value reaches, irrespective of output enabled/disabled.

Reset Enable/Disable: Device can be reset through 4 different ways. Reset Disable - Device will set as non-resettable.

Auto reset allows user to reset Time or Count Automatically if $Rt - Y$. Auto reset is enable, if Alarm value is enable. For Counter:- If output type is Latch, then device will reset after acknowledged. If output type is time out, then device will reset after time out. For Hour meter:- Device will reset hour meter after acknowledged

Front reset allows user to reset Time or Count by pressing RST key for 2 sec. Terminal reset allows user to reset Time or Count by shorting reset terminal to ground for minimum 80 mS .

Power ON reset: PorSt n - Count / time retains at power ON. PorSt y - Count / time resets at power ON.

Contrast control: Using this function contrast level of LCD can be adjusted from 0 to 7. Refer Scr 30 & Scr 31

Password change: Password is required for editing the parameter. User can set password value in between 01 to 99. 00 – Password Disabled, 01- 99 – Password Enabled, 72 - Master Password.

Save: Confirmation to save edited parameter. Refer Scr 33 to Scr 34. Save Y - Saves the edited parameter in memory. Save N - It will not save edited parameter.

NOTE: Edit Mode timeout time: 45 sec.

Counter Flow:

Auto reset is not applicable for Down counter.

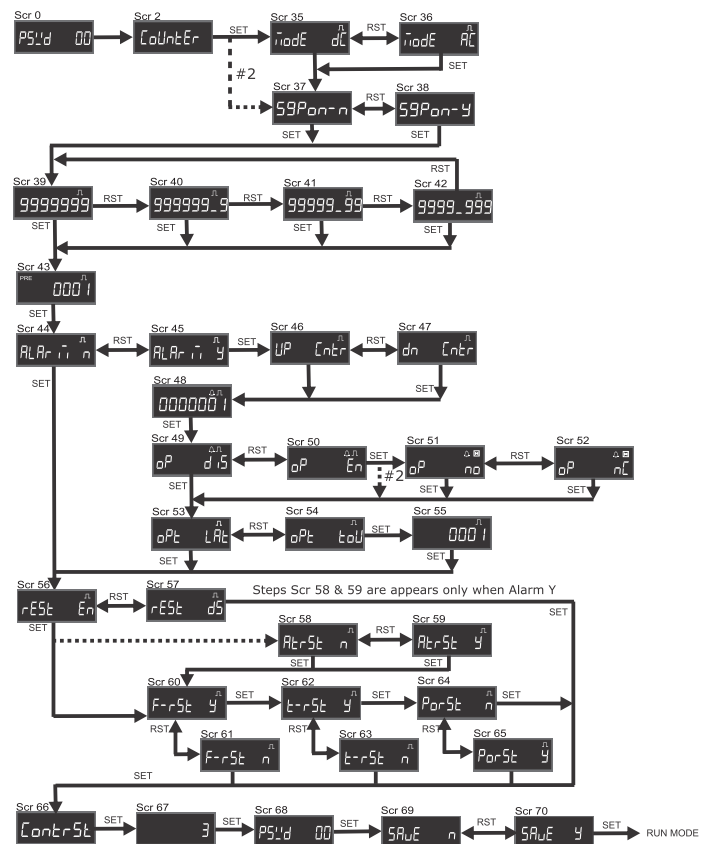

Input signal selection:

Note: This part is applicable for AC-DC product only. Refer Scr 35 & Scr 36. $Mode AC$ for AC signal selection. $59P_{on-n}$ - There is no increment in count if signal is present at power ON. $59P_{on-y}$ - Increments the count if signal is present at each power ON. Refer Scr 37 & Scr 38.

Decimal point selection:-

Four decimal point position selection available. Refer Scr 39 to Scr 42.

Prescaler :- It means number of pulses required to increment display value by 1. User has to select Decimal point position(Resolution) as per prescaler value set.
e.g. Lets say if application is of bottle counting & 10 bottles per box. So select Prescaler as 10, Set decimal point as 1, then after 10 pulses, it increments display value by 1 and for one pulse, it increments display by 0.1.If the same application is considered as 125 bottles per box, then select prescaler as 125, Set decimal point as 3, then after 125 pulses it increments display value by 1 and for one pulse,it increments display by 0.008. Refer Scr 43

Alarm value selection :- Refer Scr 44 to Scr 48.

Up counter functionality is recurring alarm type, output turns on every time after alarm value reaches & it continues the counting.

Down counter functionality is Preset type. It starts from alarm value & when value reaches to zero output turns on. Auto reset is not applicable for Down counter.

Note: After changing Alarm value, if new Alarm value less than Current value then, out put turns on at display value equal to (Current value + alarm value). If new alarm value is greater than current display value then, output turns on at alarm value.

Output Enable / Disable: Using this setting output can be made either enabled Or disabled. Refer Scr 49 to Scr 52.

Output Type :- There are two type of output functionality. Refer Scr 53 to Scr 55.

Latch: Once Alarm Value reaches, Output becomes ON and remains ON until it gets acknowledged.
It also retains its state after power OFF/ON cycle.

Time out: When output turns ON it remains ON till the timeout period, which is in seconds. Timeout value can be set from 1 to 9999

After this screen for Reset types, Contrast & setting same Screen 20 to 34 will appear in order.

Note:-

In counter for 1,2,3 decimal point, when display value is greater than 7 digit, then device will show "roll over". If device shows rollover then select the lower decimal point position. In No decimal point - after rollover value will reset to zero.